

LABELLING

All important markings on the label

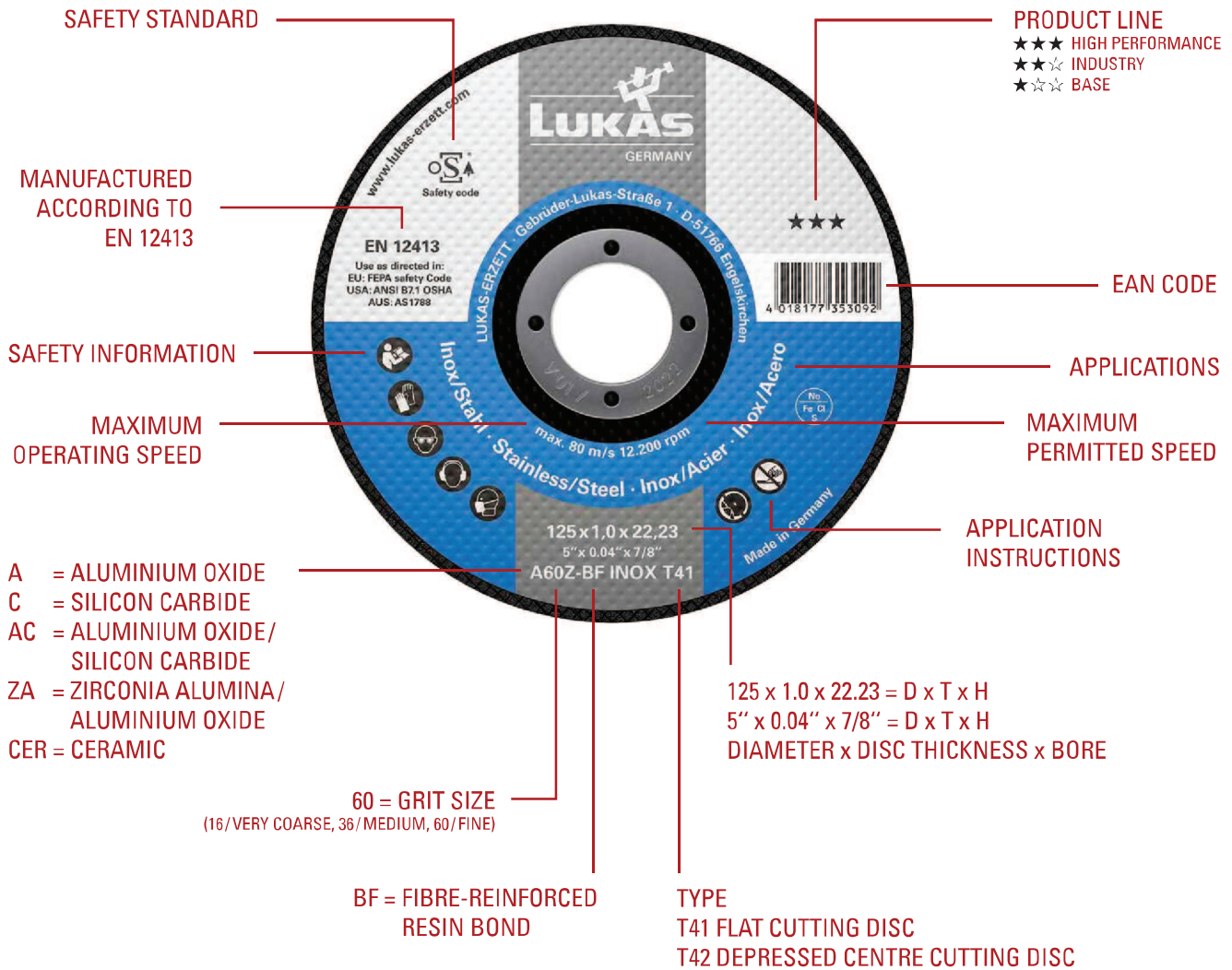
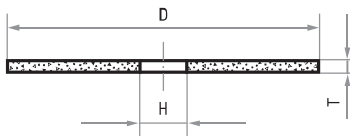
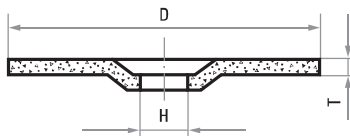

TYPES OF RESIN-BONDED CUTTING DISCS

T41 Flat cutting discs	T42 Depressed centre cutting disc
 <p>Cutting discs T = (0.8 mm–4.5 mm) (USA: Type 1)</p>	 <p>Cutting discs T = (0.8 mm–4.5 mm) (USA: Type 27)</p>
<ul style="list-style-type: none"> Available in diameters from 50 mm (2") to 230 mm (9"), for handheld use From 300 mm (12") to 500 mm (20") for stationary machines 	<ul style="list-style-type: none"> Available in diameters from 76 mm (3") to 230 mm (9"), approved for handheld use